

## Series VH

Three-Screw pump for high pressure applications up to 280 bar

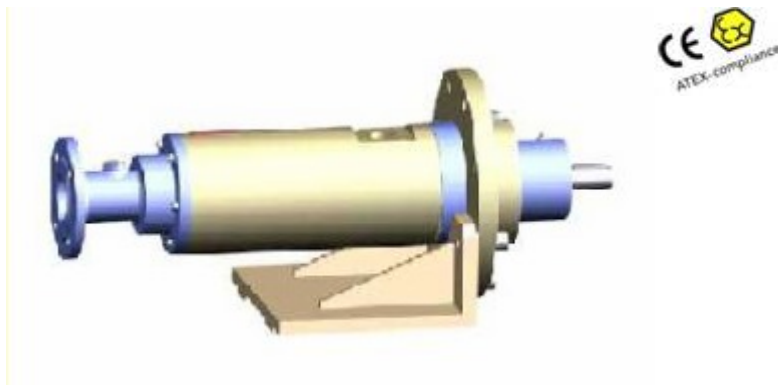

### Pumped liquid

Chemically neutral, lubricating, e.g., fuel oils, lubricating oils, hydraulic oils, cutting oils, coolant oils, cooling oils, waxes, tar oils

### Main fields of application

Firing, hydraulics, mechanical engineering, general industrial technologies, chemical and petrochemical industries, marine and offshore engineering

### Performance data Series VH

Capacity	Q	up to 1300	l/min
Inlet pressure	ps	up to 16	bar
Discharge pressure	pd	up to 280	bar
Differential pressure	pdiff	up to 280	bar
Viscosity	v	up to 3..1500	mm <sup>2</sup> /s
Fluid temperature	t	up to 150	°C
Speed	n	up to 3600	1/min

### Construction features

- Bulkhead mounting
- Dry installation
- Submerged design
- In-tank installation
- Vertical installation
- Horizontal installation
- Self - priming
- With shaft sealing