

Axial piston pumps type PVPC

variable displacement, by a full line of mechanical controls

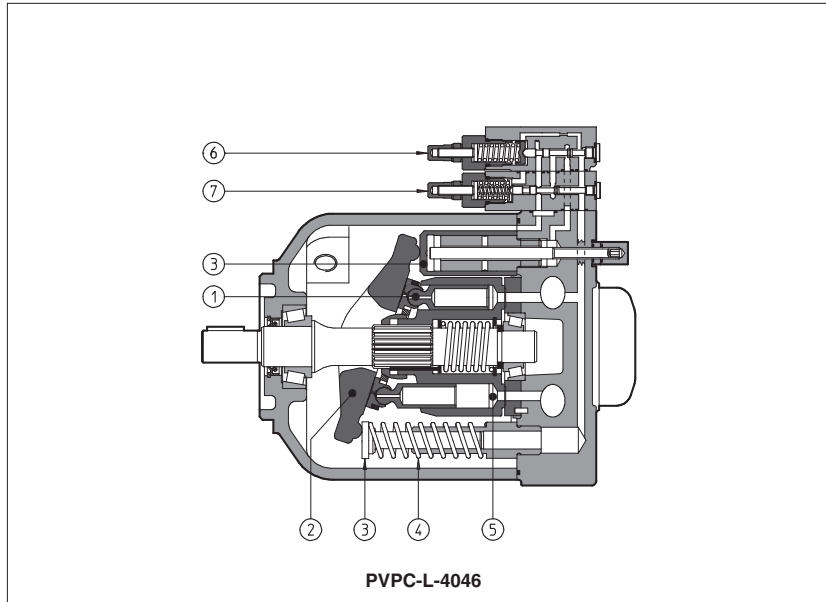

PVPC are variable displacement axial piston pumps for high pressure operation, with low noise level, suitable for hydraulic oils or synthetic fluids having similar lubricating characteristics.

The actual displacement is dependent on the length of stroke of the pumping pistons ①. This length of stroke is determined by the position of the swashing plate ② that is achieved by two servo pistons ③ with differential areas, against a spring ④.

The rotating barrel ⑤ forces the pistons in a circular path in and out of the barrel and fluid displacement takes place.

Typical section on side shows version L with manual pressure compensator ⑥ and flow regulation ⑦.

The available hydraulic controls are shown in sections 8. The wide range of electrohydraulic proportional controls is shown in tab. A170.

SAE J744 mounting flange and shaft (see note 1).

Max displacement: 29-46-73-88 cm³/rev.
Max pressure: 280 bar working
350 bar peak.

1 MODEL CODE

PVPC

X2E - C - 4 046 / 31044 / 1 D - X

24DC 10 /*

Variable displacement axial piston pump

Additional suffix for pumps with through shaft:
XA = intermediate flange SAE A
XB = intermediate flange SAE B
XC = intermediate flange SAE C (only for size 5)

Additional suffix for double pumps:
X2E = with a fixed displacement pump type PFE (see tab. A005)

Type of control (see section 8):
C = manual pressure compensator
CH = manual pressure compensator, with venting
R = remote pressure compensator
L = load sensing (pressure & flow)
LW = constant power (combined pressure & flow)
For electrohydraulic proportional controls, see table A170

Size:
3 = for displacement 029
4 = for displacement 046
5 = for displacement 073 and 090

Max displacement of axial piston pump (1):
029 = 29 cm³/rev
046 = 46 cm³/rev
073 = 73 cm³/rev
090 = 88 cm³/rev

Seals material:
omit for NBR (mineral oil & water glycol)
PE = FPM
See notes in section 2

Supply voltage, see section 5 (only for CH version)

X = without connector (only for CH version)
See section 4 for available connectors, to be ordered separately

Direction of rotation (viewed at the shaft end)
D = clockwise
S = counterclockwise

Shaft (SAE Standard) (2):
1 = keyed (7/8" for 029 - 1" for 046 - 1 1/4" for 073 and 090)
5 = splined (13 teeth for 029 - 15 for 046 - 14 for 073 and 090)

Type of PFE (for double pumps), see tab. A005

- 1) optional intermediate displacements 35 and 53 cc/rev are available on request
- 2) pumps with ISO 3019/2 mounting flange and shaft (option /M) are available on request

2 OPERATING CHARACTERISTICS

Pump model	PVPC*-3029	PVPC*-4046	PVPC*-5073	PVPC*-5090
Displacement [cm ³ /rev]	29	46	73	88
Theoretical max flow at 1450 rpm [l/min]	42	66,7	105,8	127,6
Max working pressure / Peak pressure [bar]	280/350	280/350	280/350	250/315
Min/Max inlet pressure [bar abs.]	0,8 / 25	0,8 / 25	0,8 / 25	0,8 / 25
Max pressure on drain port [bar abs.]	1,5	1,5	1,5	1,5
Power consumption at 1450 rpm and at maximum pressure and displacement [kW]	19,9	31,6	50,1	54,1
Max torque on the first shaft [Nm]	Type 1 210	Type 1 350	Type 1 670	Type 1 670
	Type 5 270	Type 5 440	Type 5 810	Type 5 810
Max permissible load on drive shaft [N]	F _{ax} 1000	F _{ax} 1500	F _{ax} 2000	F _{ax} 2000
	F _{rad} 1500	F _{rad} 1500	F _{rad} 3000	F _{rad} 3000
Speed rating [rpm]	500 ÷ 3000	500 ÷ 2600	500 ÷ 2600	500 ÷ 2200

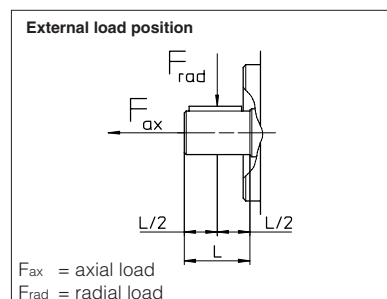

Notes: For speeds over 1800 rpm the inlet port must be under oil level with adequate pipes.
Maximum pressure for all models with water glycol fluid is 160 bar, with option /PE is 190 bar.
Max speed with options /PE and for water glycol fluid is 2000/1900/1600/1500 rpm respectively for the four sizes.

3 MAIN CHARACTERISTICS OF VARIABLE DISPLACEMENT AXIAL PISTON PUMP TYPE PVPC

Installation position	Any position. The drain port must be on the top of the pump. Drain line must be separated and unrestricted to the reservoir and extended below the oil level as far from the inlet as possible. Suggested maximum line length is 3 m.		
Ambient temperature	from -20°C to +70°C		
Fluid	Hydraulic oil as per DIN 51524...535; for other fluids see section 11		
Recommended viscosity	15÷100 mm ² /sec at 40°C (ISO VG 15÷100). Maximum start-up viscosity: 1000 mm ² /sec		
Fluid contamination class	ISO 4401 class 21/19/16 NAS 1638 class 10 (filters at 25 µm value with β ₂₅ ≥ 75 recommended)		
Fluid temperature	-20°C +60°C	-20°C +50°C (water glycol)	-20°C +80°C (seals /PE)

3.1 Coils characteristics (for version CH)

Insulation class	H
Connector protection degree	IP 65
Relative duty factor	100%
Supply voltage and frequency	See electric feature 9
Supply voltage tolerance	± 10%

4 ELECTRIC CONNECTORS ACCORDING TO DIN 43650 FOR VERSION CH

The connectors must be ordered separately

Code of connector	Function
SP-666	Connector IP-65, suitable for direct connection to electric supply source
SP-667	As SP-666 connector IP-65 but with built-in signal led, suitable for direct connection to electric supply source

5 ELECTRIC FEATURES FOR VERSION CH

External supply nominal voltage ±10%		Power consumption	Nominal current	Coil characteristics	
DIRECT CURRENT	12 DC	19,2 W	1,61 A	Insulation Class: H	
	24 DC		0,80 A		
ALTERNATE CURRENT	24/50 AC	19 W	0,89 A		Protection degree: IP65
	110/50 AC		0,19 A		
	220/50 AC		0,09 A		

Average values based ambient/coil temperature of 20°C.

6 INSTALLATION POSITION

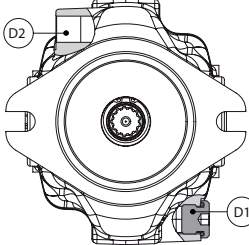
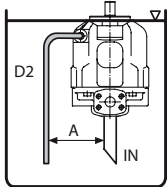
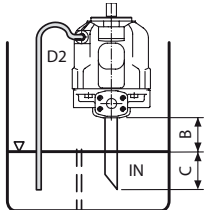
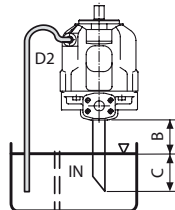
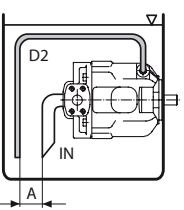
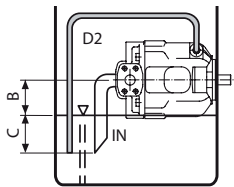
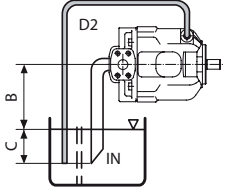
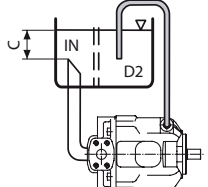
 <p>The pump is supplied with drain D2 open, and D1 plugged. Before installation fill the pump with hydraulic oil for at least 3/4 of its volume, keeping it in horizontal position. With exception of pump mounted below the oil level, we recommend to interpose a baffle plate between inlet and drain line.</p>	VERTICAL INSTALLATION		
	 <p>INSIDE THE TANK Minimum oil level equal or above the pump mounting surface. A ≥ 200mm</p>	 <p>INSIDE THE TANK Minimum oil level below the pump mounting surface. Minimum inlet pressure = 0,8 bar absolute B ≤ 800mm, C = 200mm</p>	 <p>OUTSIDE THE TANK, above oil level Minimum inlet pressure = 0,8 bar absolute B ≤ 800mm, C = 200mm</p>
HORIZONTAL INSTALLATION			
 <p>INSIDE THE TANK Minimum oil level equal or above the pump mounting surface. A ≥ 200mm</p>	 <p>INSIDE THE TANK Minimum oil level below the pump mounting surface. Minimum inlet pressure = 0,8 bar (absolute) B ≤ 800mm, C = 200mm</p>	 <p>OUTSIDE THE TANK, above oil level Minimum inlet pressure = 0,8 bar (absolute) B ≤ 800mm, C = 200mm</p>	 <p>OUTSIDE THE TANK, below oil level C = 200mm</p>

IN: inlet line - D1: drain line - A: minimum distance between inlet and drain line - B+C: permissible suction height - C: inlet line immersion dept

7 DIAGRAMS at 1450 rpm (based on mineral oil ISO VG 46 at 50°C)

7.1 Noise level curves

Ambient noise levels measured in compliance with ISO 4412-1 oleohydraulics - Test procedure to define the ambient noise level - Pumps
 Shaft speed: 1450 rpm.

— = Qmax - - - - - = Qmin

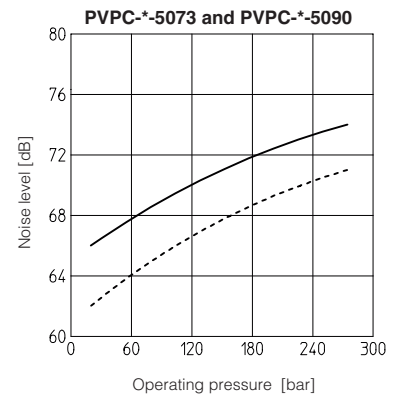
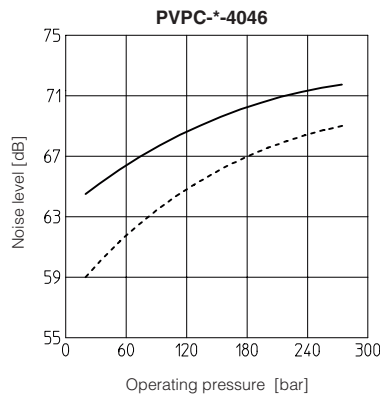
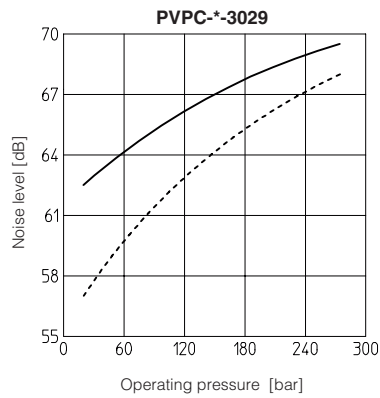

7.2 Operating limits

- 1 = Volumetric efficiency
- 2 = Overall efficiency
- 3 = Flow versus pressure curve
- 4 = Power consumption with full flow
- 5 = Power consumption at pressure compensation

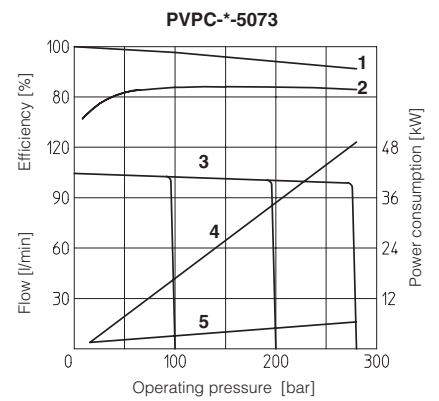
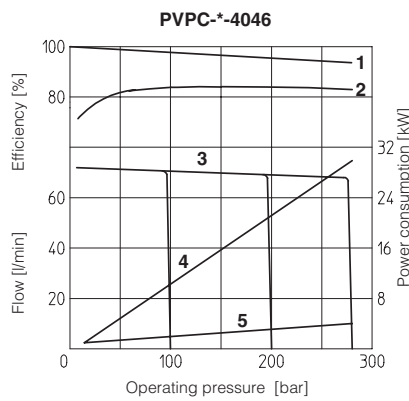
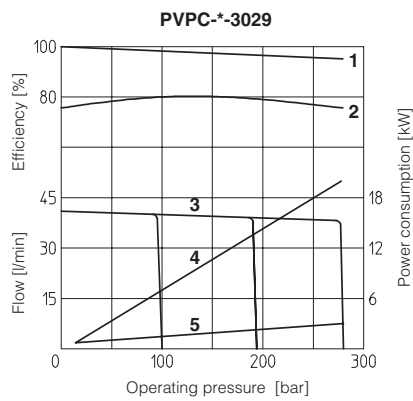

7.3 Response times

7.3.1 Response times and pressure peak due to variation 0% Ø 100% Ø 0% of the pump displacement, obtained with an instantaneously opening and shut-off of the delivery line.

Pump type	T1 (ms)	T2 (ms)
PVPC*-3029	31	19
PVPC*-4046	44	20
PVPC*-5073	50	25
PVPC*-5090	53	28

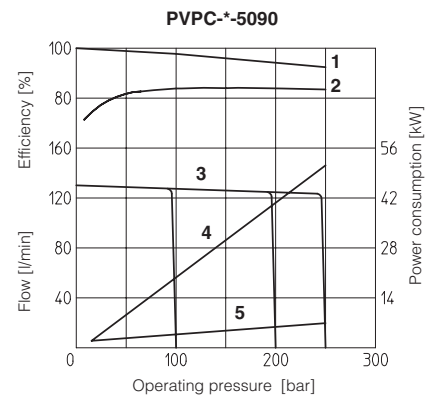
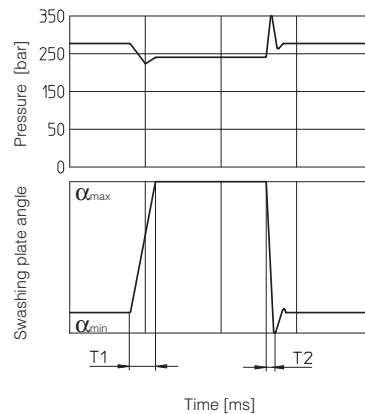

7.3.2 Variation of inlet pressure and reduction of displacement with increasing speed rating

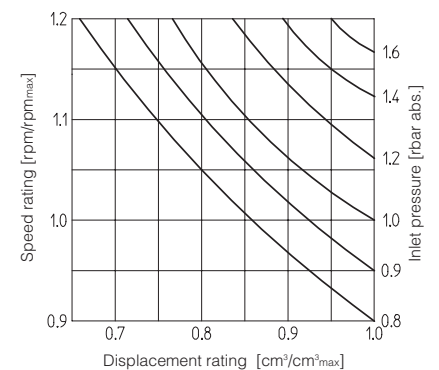

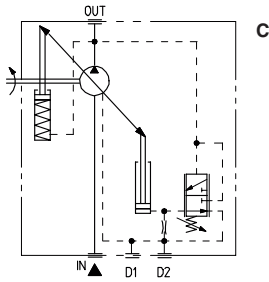

Manual pressure compensator

The pump displacement decreases when the line pressure approaches the setting pressure of the compensator. The pump supplies only the fluid required by the system. Pressure may be steplessly adjusted at the pilot valve.
 Compensator setting range: 20 ÷ 350 bar (315 bar for 090)
 Compensator standard setting: 280 bar (250 bar for 090)

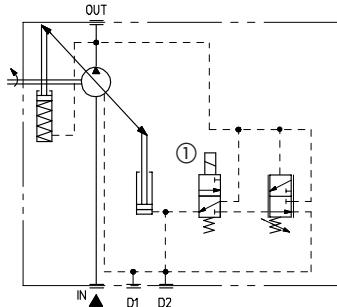
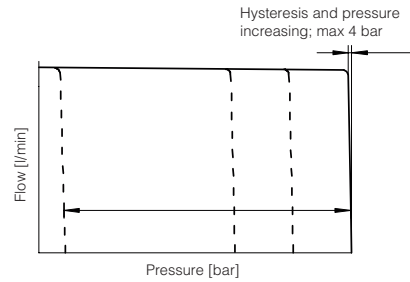

CH Manual pressure compensator with venting

As C plus venting function, when a long unloading time is required and heat generation and noise have to be kept at lowest level.
 Venting valve solenoid voltage, see section 5
 Venting valve OFF = null displacement
 Venting valve ON = max displacement
 Compensator setting range: 20 ÷ 350 bar (315 bar for 090)
 Compensator standard setting: 280 bar (250 bar for 090)

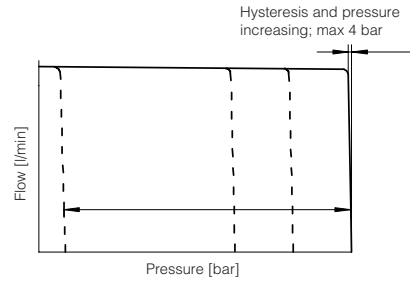

① solenoid venting valve

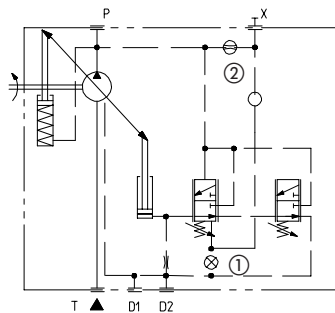

R Remote pressure compensator

As C, but with remote setting of the compensator by means of a pressure relief valve on the piloting line X.
 This version can be obtained from version L using a blind plug UNI 5923 M4x12 in pos. ① and a restrictor M4 drilled ø 0,75 mm in pos. ②.
 Compensator setting range: 20 ÷ 350 bar (315 bar for 090)
 Compensator standard setting: 280 bar (250 bar for 090)

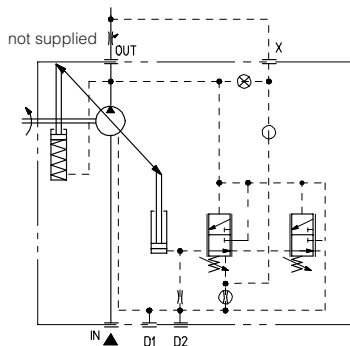
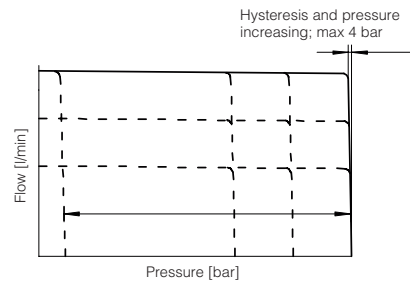

L Load sensing

The pump displacement is automatically adjusted to maintain a constant (load independent) pressure drop across an external throttle. Changing the throttle regulation, the pump flow is consequently adjusted.
 Load sensing control always incorporates an hydraulic compensator to limit the maximum pressure.
 Compensator setting range: 20 ÷ 350 bar (315 bar for 090)
 Compensator standard setting: 280 bar (250 bar for 090)
 Differential pressure setting range: 10 ÷ 40 bar
 Differential pressure standard setting: 14 bar

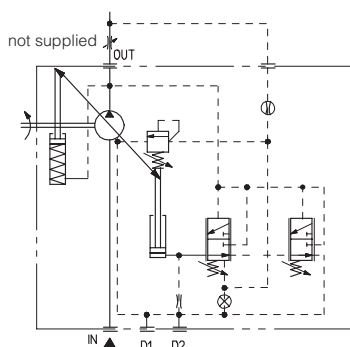
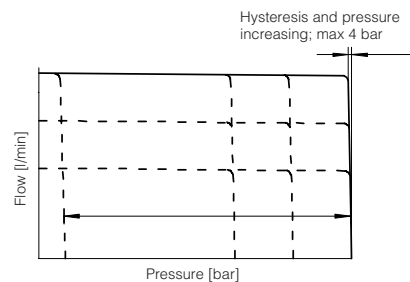

LW Constant power

In order to achieve a constant drive torque with varying operating pressure. The swashing angle and therefore the outlet flow is varied so that the product of flow and pressure remains constant.
 For the best regulation, minimum working pressure is 80 bar.
 While selecting LW control, the required value of power must be communicated with the order (ex. 10 kW at 1450 rpm).

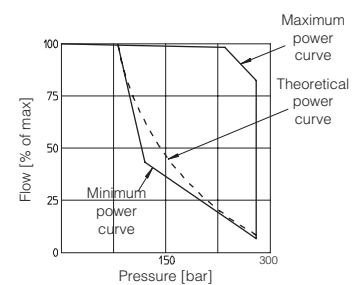

9 DIMENSIONS OF PVPC-*-3029: BASIC VERSION "C" CONTROL

PORTS DIMENSION

IN = Flange SAE 3000 1 1/4"

OUT = Flange SAE 6000 3/4"

D1, D2 = 1/2" BSPP

① = Regulation screw for max displacement 1,5 cm³/rev per turn. Adjustable range 50% to 100% of max displacement.
In case of double pump the regulation screw is not always available, please contact our technical office.

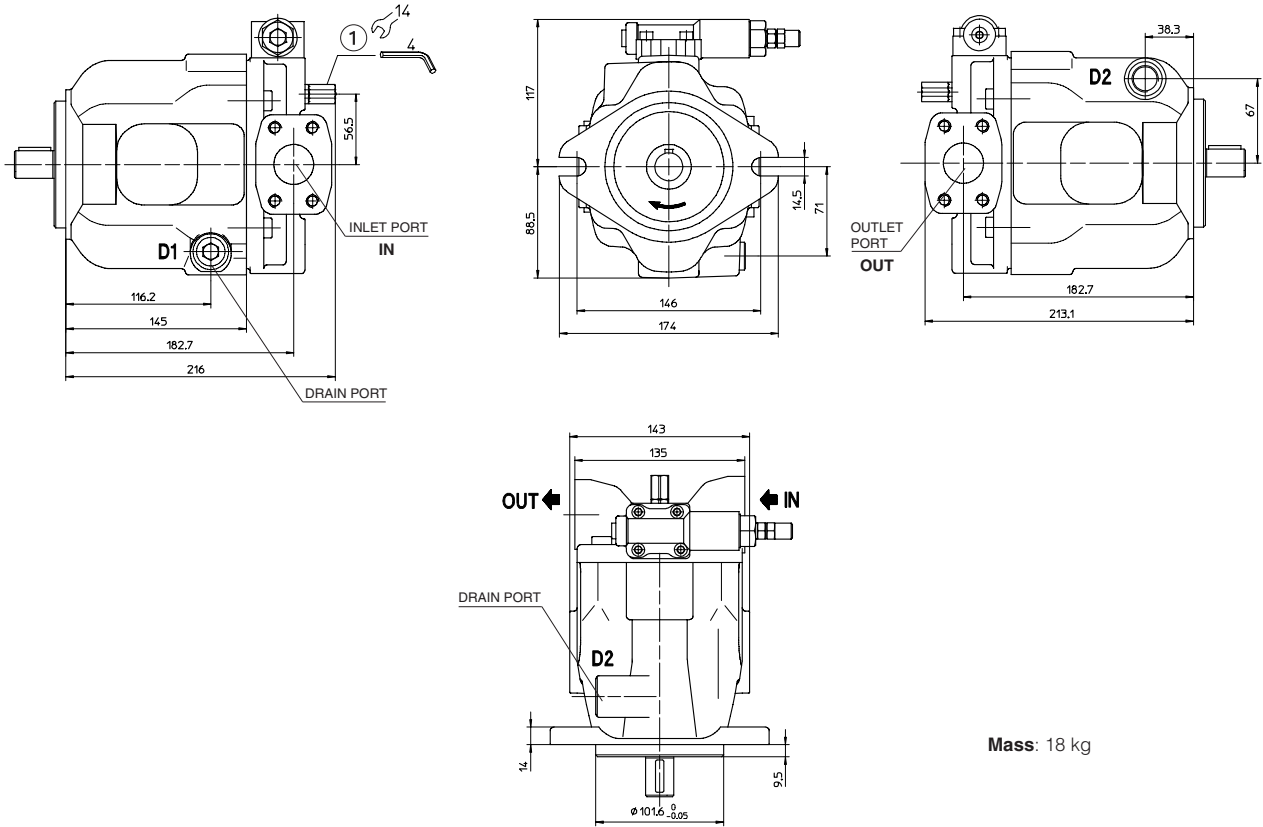

Mass: 18 kg

SHAFT TYPE "1"

SHAFT TYPE "5"

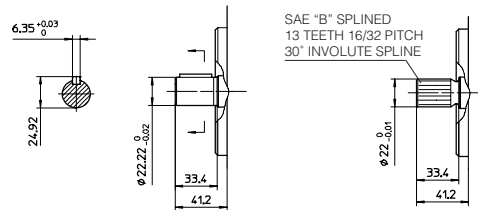

INTERMEDIATE FLANGE SAE "A" FOR PFE-31

INTERMEDIATE FLANGE SAE "B" FOR PFE-41

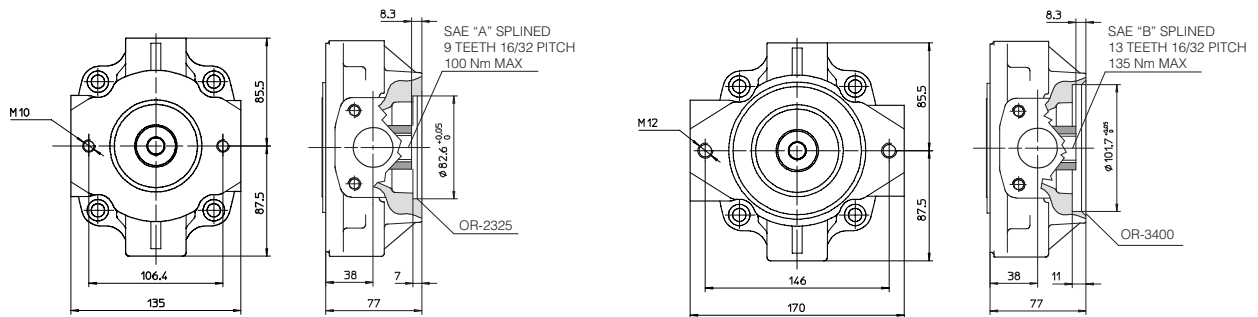

Drawing shows pumps with clockwise rotation (option D); pumps with counterclockwise rotation (option S) will have inlet and outlet ports inverted

10 DIMENSIONS OF PVPC-*-4046: BASIC VERSION "C" CONTROL

PORTS DIMENSION

IN = Flange SAE 3000 1 1/2"

OUT = Flange SAE 6000 1"

D1, D2 = 1/2" BSPP

① = Regulation screw for max displacement 2,2 cm³/rev per turn. Adjustable range 50% to 100% of max displacement.
In case of double pump the regulation screw is not always available, please contact our technical office.

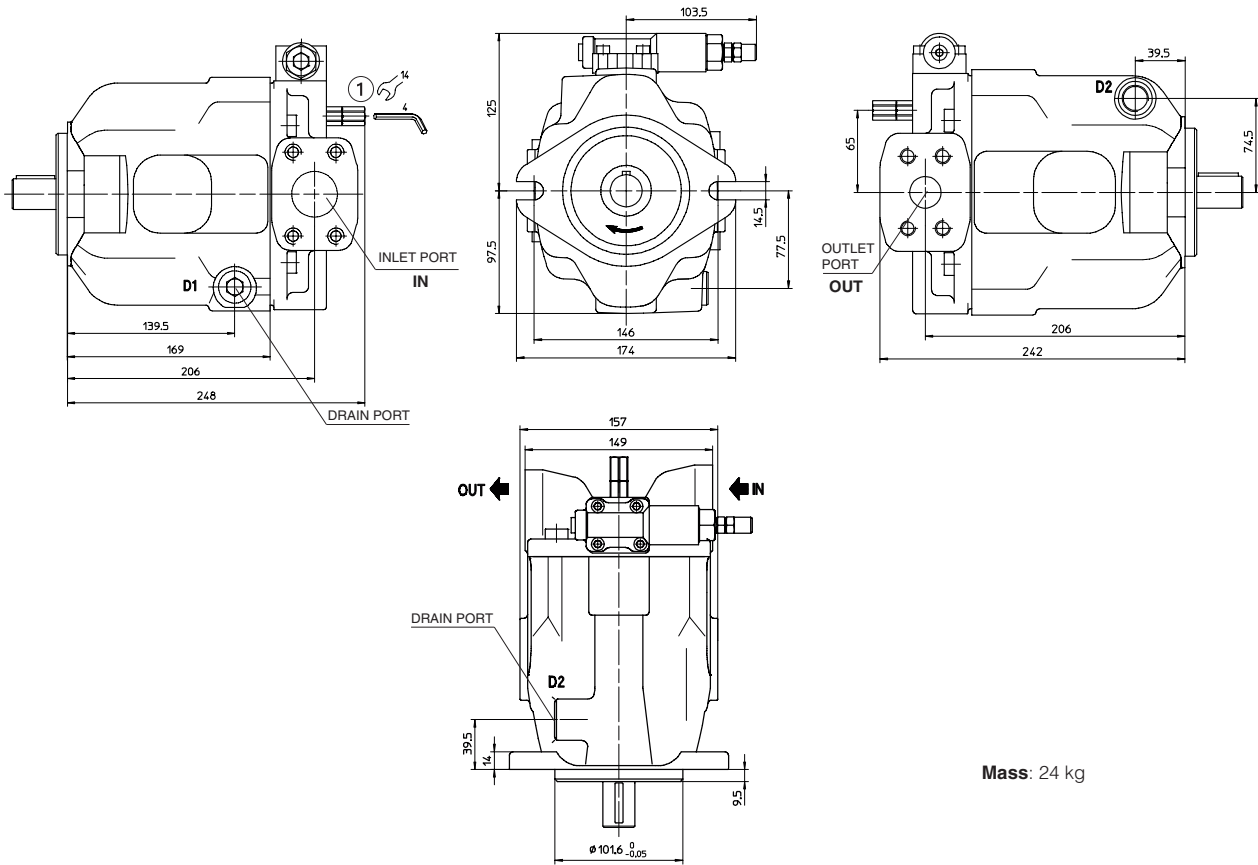

SHAFT TYPE "1"

SHAFT TYPE "5"

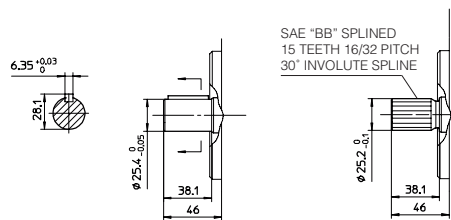

INTERMEDIATE FLANGE SAE "A" FOR PFE-31

INTERMEDIATE FLANGE SAE "B" FOR PFE-41

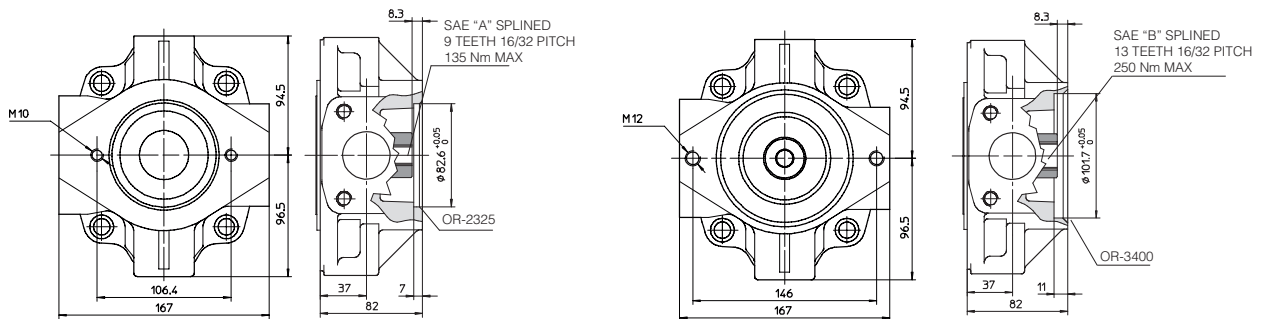

Drawing shows pumps with clockwise rotation (option D); pumps with counterclockwise rotation (option S) will have inlet and outlet ports inverted

11 DIMENSIONS OF PVPC-*-5073 and PVPC-*-5090: BASIC VERSION "C" CONTROL

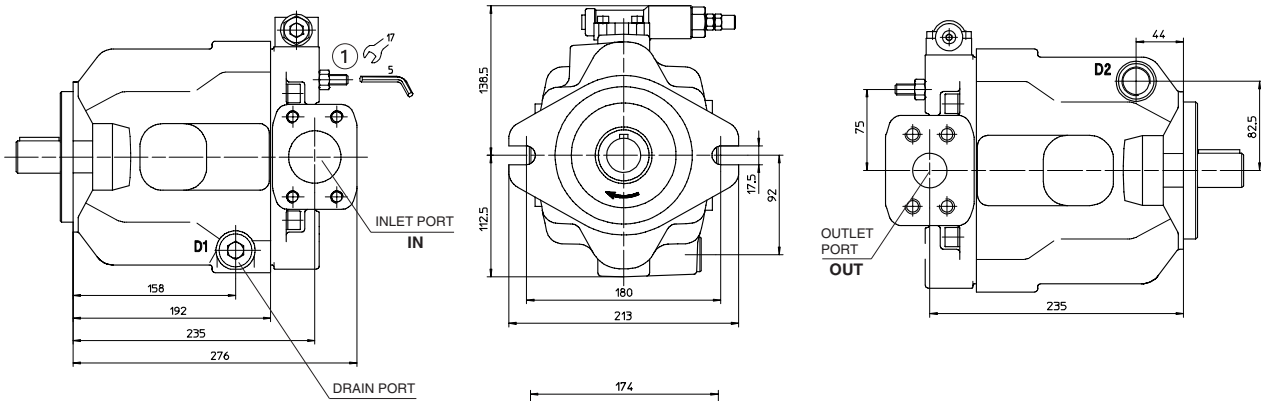

PORTS DIMENSION

IN = Flange SAE 3000 2"

OUT = Flange SAE 6000 1 1/4"

D1, D2 = 3/4" BSPP

① = Regulation screw for max displacement
3,2 cm³/rev per turn.

Adjustable range 50% to 100% of max displacement.

In case of double pump the regulation screw is not always available, please contact our technical office.

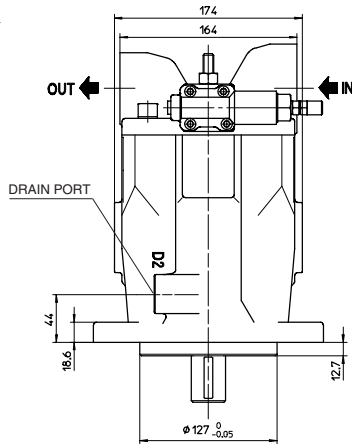

Mass: 33 kg

SHAFT TYPE "1"

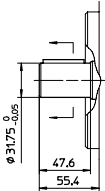

SHAFT TYPE "5"

SAE "C" SPLINED
14 TEETH 12/24 PITCH
30° INVOLUTE SPLINE

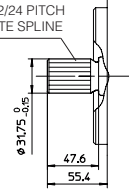

INTERMEDIATE FLANGE SAE "A" FOR PFE-31

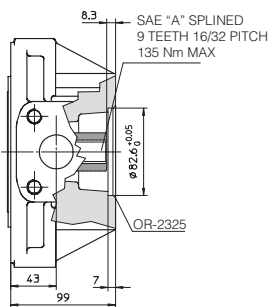
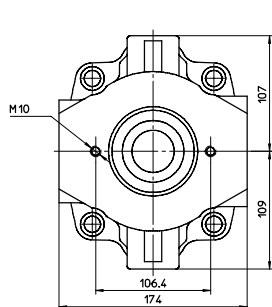

INTERMEDIATE FLANGE SAE "B" FOR PFE-41

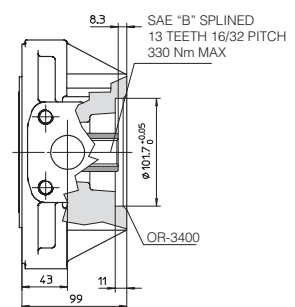
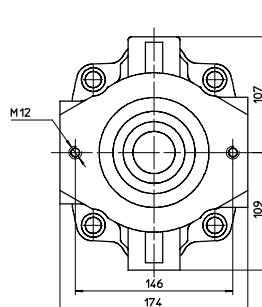

INTERMEDIATE FLANGE SAE "C" FOR PFE-51

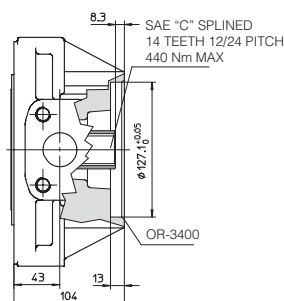
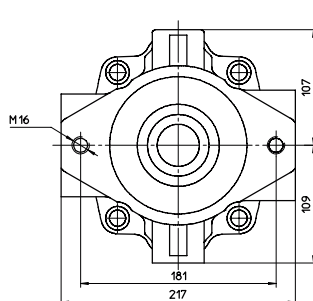

Drawing show pumps with clockwise rotation (option D): pumps with counterclockwise rotation (option S) will have inlet and outlet ports inverted

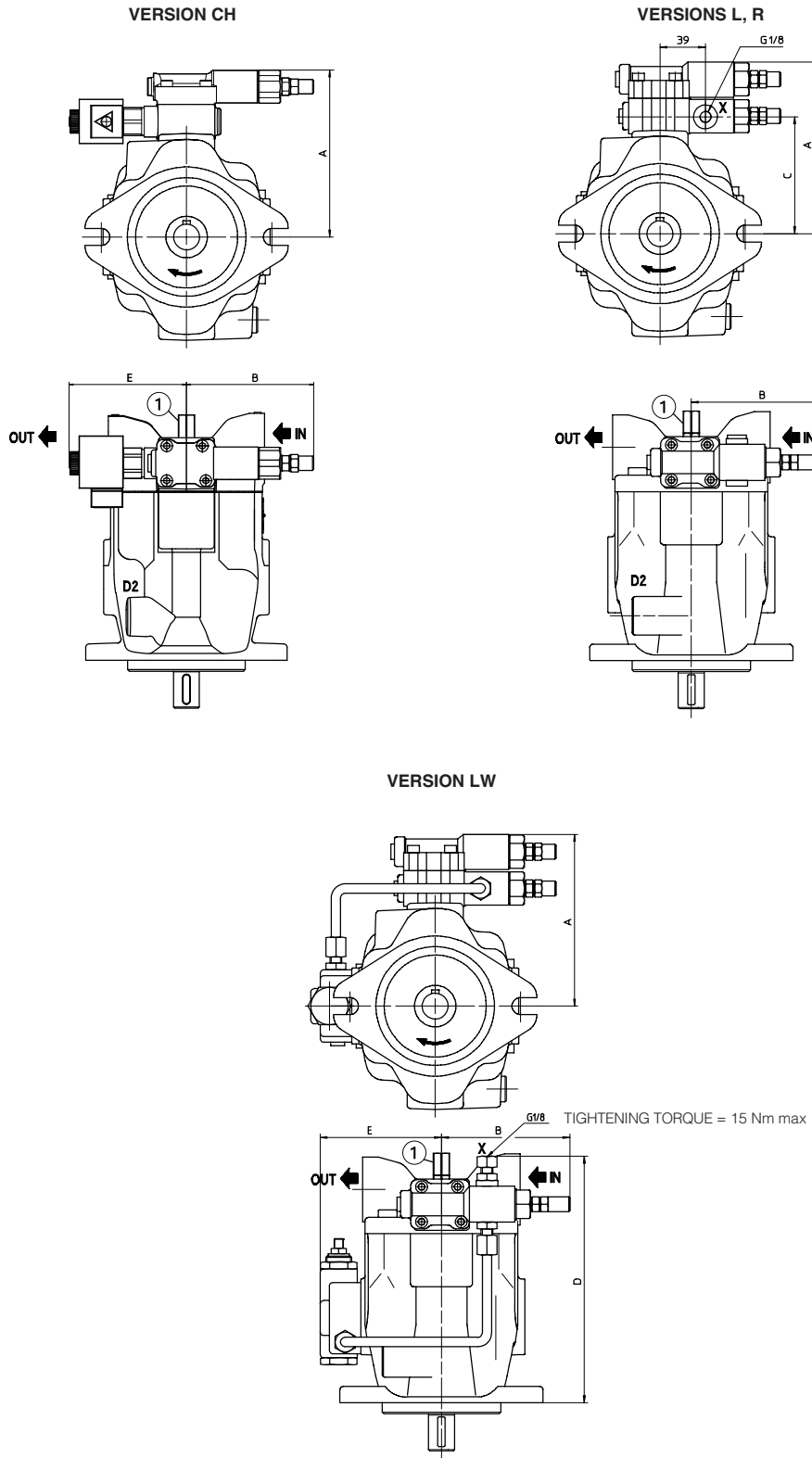

① = Regulation screw for max displacement. Adjustable range 50% to 100% of max displacement.
 In case of double pump the regulation screw is not always available, please contact our technical office.

Drawing shows pumps with clockwise rotation (option D): pumps with counterclockwise rotation (option S) will have inlet and outlet ports inverted and also the consequently position of the control groups

Pump type	Version	A	B	C	D	E	Mass (kg)
PVPC-*-3029	CH	144	111	-	-	102	22
	L-R	144	111	100	-	-	19,2
	LW	144	111	-	211	104	20
PVPC-*-4046	CH	153	111	-	-	102	28
	L-R	153	111	109	-	-	25,2
	LW	153	111	-	235	111	26
PVPC-*-5073	CH	166	111	-	-	102	36,9
PVPC-*-5090	L-R	166	111	122	-	-	34,2
	LW	166	111	-	258	120	35